



Battery Accessories



Simple Mounting Bracket

- 2U for LS50, 522*131mm
- 3U for LS75 and ES100 II, 522*172*398mm
- Support up to 4 pcs lithium batteries



Power Rack Lithium Battery Rack Cabinet

- IP65
- For installation of 6xLS50 or 4xLS75 or 4xES100 II



PDP-LS

- 1 x 100A DC circuit breaker
- Rack-mounted
- IP20
- Work with LS50/LS75, a set of power cable needs to be equipped with a PDP



PDP-ES

- 1*300A DC switch
- Rack-mounted
- IP20
- Work with ES100, a set of power cable needs to be equipped with a PDP



Positive Power Cable



Negative Power Cable

Lihtium Battery Connection HUB

LS-HUB

Support Up to 40 units Super L modules

For Super L lithium battery system parallel connection



TBB LS HUB is used for TBB Super L lithium battery system parallel connection, to analyze the data of the parallel lithium battery modules and transfer the data to inverters.

It is recommended to use TBB LS HUB when more than 8 Super L lithium battery modules are connected in parallel. With excellent performance and design, TBB LS HUB can support up to 40 Super L lithium battery modules connected in parallel.

- Multi Battery Groups CAN Communication Cable Connection
- Each LS HUB supports up to 5 battery groups connected in parallel
- Each battery group can configure 8pcs LS50 or 8pcs LS75

No .	Item	Parameter
1.	Operating Voltage Range	48VDC/220VAC
2.	Communication Interface	CAN/RS485
3.	System Consumption	5W
4.	Size (L*W*H)	480*307*44mm
5.	Protection Degree	IP20
6.	Weight(kg)	2
7.	Working Humidity	5%~85%RH without condensation
8.	Working Temperature	-40°C~60°C
9.	Storage temperature	-55°C~125°C
10.	CAN(Max 5 groups)	Baud rate: 500K/250K; terminal resistance:120 Ω
11.	RS485(Max 5 groups)	Baud rate: 9600/115200

Communication Cable Wiring Diagram 1

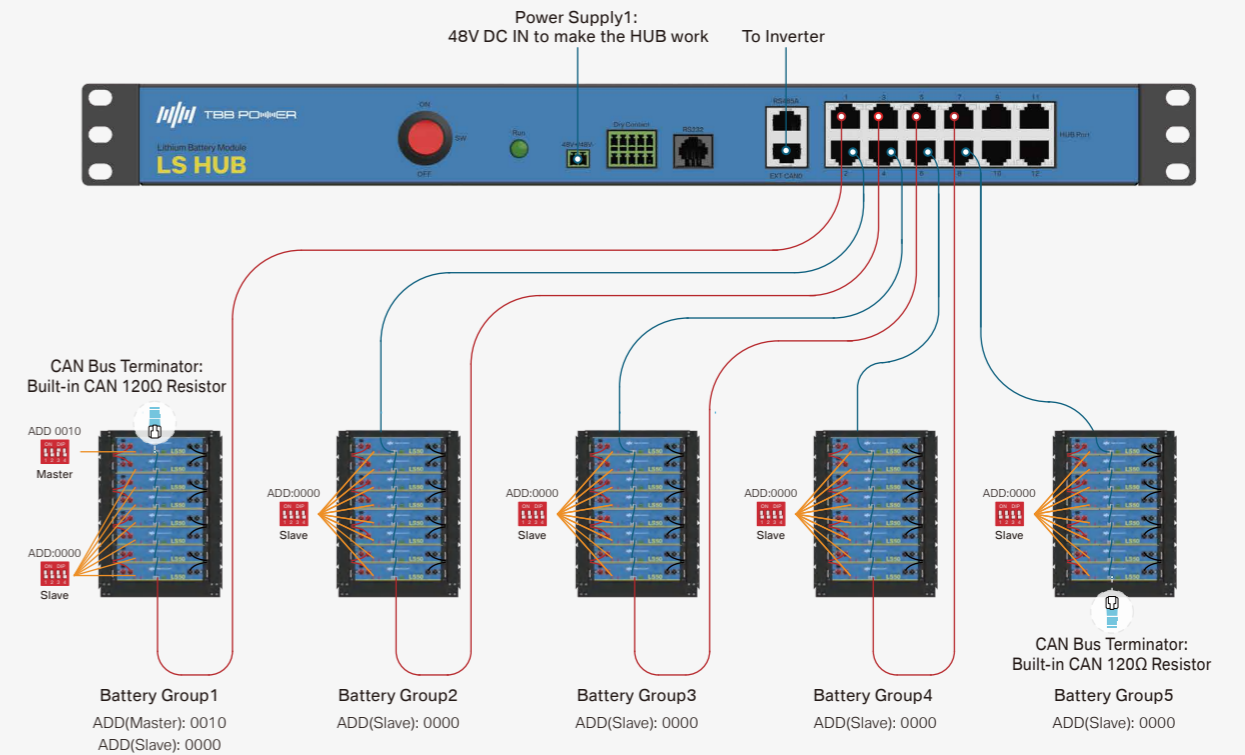

Communication Cable Wiring Diagram 2

